

Use of Cr-39 Polymer for Radiation Dosimetry

Zuhair A. Tayyeb

*Department of Nuclear Engineering, College of Engineering,
King Abdulaziz University, P.O. Box 80204, Jeddah 21589, Saudi Arabia
ztayyeb@hotmail.com*

Abstract. This paper discusses the results of investigations of beta and gamma radiation induced thermoluminescence (TL) of CR-39 polymer. As the material is cheap and easily available, the feasibility of CR-39 being used for personal dosimetry is worth investigating. Samples from CR-39 of dimensions 3mm × 3mm were classified into two main groups. The first group was irradiated with gamma rays from ¹³⁷Cs source, while the second group was exposed to beta particles from ⁹⁰Sr source and read for TL emission on a TLD reader, Harshaw 4500. The chips were annealed at different temperatures to find out optimum annealing temperature to get rid of the background to a maximum. Different annealing times were also studied for optimization. The heating temperatures in the TL reader were studied in a wide range so as to assess the best possible heating temperature. The possible enhancement of TL response of CR-39 exposed to gamma rays in the presence of oxygen and carbon dioxide was also studied. Dose response of CR-39 exposed to gamma rays in the presence of oxygen is better than that in the presence of carbon dioxide. The response of the exposed polymer in the presence of carbon dioxide is found to be better than that in the presence of air.

Keywords: CR-39 polymer ; TL response ; ⁹⁰Sr ; ¹³⁷Cs ; Oxygen effect ; Carbon dioxide effect.

1. Introduction

CR- 39 is the trade name of polyallyl diglycol carbonate (PADC). It is a polymer having chemical composition C₁₂H₁₈O₇. It is a class of plastic detectors which has been most widely used for the charged particles detection and measurement and also for neutron dosimetry^[1-8].

Irradiation of polymeric substances by high energy ionizing radiation such as x-rays or gamma rays causes many changes in the

polymer. It may degrade polymeric materials by random fracture of the main chain with the number of fractures being proportional to the radiation dose^[9-12]. The bond breaking may give rise to free radicals^[9,11], ionic species, water molecules, gaseous products, etc.^[10,11,13]. It has been reported that CO₂ molecules are produced in irradiated CR-39 plastic by gamma ray (or x-ray) and the production of CO₂ was attributed to bond breaking in the CR-39 plastic by radiation^[3,10,11,14]. This CO₂ is trapped inside, this can lead to the subsequent crazing and cracking of the plastic due to accumulated local stress^[11,14]. The production of CO₂ is a function of gamma ray dose^[11,15].

Several authors^[16-19] studied the effects of electron beam on CR-39 polymer and found that the material undergoes structural, physical and chemical modifications induced by the incident electrons energy transfer in the substrate. This is similar to the processes generated by the secondary electrons created during ion beam polymer interactions.

The environment present during irradiation can significantly affect the properties of the polymeric material. For example, the presence of O₂ or air during irradiation produces free radicals that are often rapidly converted to peroxide radicals^[20-23].

Different authors have also been exploring the possibility of using CR-39 polymer for neutron, UV, X-ray and gamma ray dosimeters by changing the properties of this polymer under different experimental conditions^[24-31].

The aim of the present study is not only to obtain information concerning the thermoluminescence response of the CR-39 polymer to beta particles and gamma rays but also to observe the enhancement of TL response of CR-39 exposed to gamma-rays in the presence of oxygen and carbon dioxide. The background TL emission from the CR-39 chips were also assessed. The chips were annealed at different temperatures for different times to obtain optimum annealing condition to get rid of the background to a maximum.

2. Materials and Methods

2.1 Preparation of CR-39 TL Chips

Transparent sheets of CR-39 purchased from Pershore Moulding Ltd, England were used in this study. The sheets were cut carefully to

square shaped chips of size 3mm × 3mm. Even though this cutting process was done with utmost care, there were limitations in obtaining chips of exactly the same size. Those pieces with cracks and lines on them were discarded. These chips were then cleaned thoroughly with distilled water and then with acetone to get rid of dirt if any before any reading or irradiation process^[2,9,12].

The CR-39 chips thus prepared were supposed to have several excited atoms as they might have been exposed to background radiation ever since they were manufactured. Also they could have been exposed to some of the sources in the laboratory inadvertently. So the unannealed chips were expected to give some TL intensity once they were read using a TL reader.

2.2 The TL Reader

The TL reader used in this study was “Harshaw 4500”, manufactured by Bicorn, U.K. The machine is a workstation used for thermoluminescent dosimetry (TLD) measurement of a wide variety of TL materials in many forms and sizes. In this reader, there are two photomultiplier tubes in a sliding housing for rapid reading of whole body and environmental TL cards, extremity dosimeters (chipstrates), TL chips, disks, rods and powders. The TL element may be heated by hot gas or by a planchet. The planchet system that is being used in this work uses electric resistance heating to produce temperatures upto 400°C. The workstation includes a personal computer with the Harshaw “Radiation Evaluation Management System” (TLD-REMS) software.

There are ten sets of four time temperature profiles and acquisition parameters stored in the memory of the system. Accurate conversion of data from charge to dosimetric units may be done using Reader Calibration Factor (RCF).

The TL charge is collected from the chips in 200 data points along the Time Temperature Profiles. The integral of these or separate Region of Interest (ROI) data may be obtained for analysis. There is also an Electronic Reference Light built into photomultiplier tube (PMT) housing for monitoring the performance of the instrument.

2.3 Heating Temperatures

The unannealed TL chips of CR-39 were now read in the TLD reader at different heating temperatures. The ultimate purpose of doing so

was to establish the temperatures for which the TL response was optimum. The heating temperatures chosen were from 50°C to 300°C. Such a selection of temperatures was done without any concern for the change in structure of material or other features of the chips that might occur during heating. The parameters fed to the reader were the following: Preheating temperature: 50°C, and the acquire time: 20 sec.

The temperatures were set in the “Time Temperature Profile” menu and a minimum of three chips were read for each temperature. The experiment was done for 50, 100, 150, 200, 250 and 300°C. Since the color of the chip turned brown at higher temperatures, it is likely that higher heating temperatures have an impact on the structure of the material and consequently on the response to radiation as well as the re-use of the material. A graph was drawn to find out the change of the TL emission intensities with heating temperatures. The same process was then repeated as a process of refinement for temperatures ranging from 150 to 300°C at intervals of 10°C. In order to further refine, the TL responses were measured at every one degree for a temperature range from 250 to 300°C. There was no specific intention in selecting the range of temperature from 150 to 300°C other than a random selection to study the variation of the emission at short intervals of temperatures. In all three cases, the results were tabulated and corresponding graphs were drawn to study the variation of emission intensities with heating temperatures.

2.4 Annealing Temperatures

The dependence of the background on annealing temperature was studied. For this, the chip samples were annealed in an oven at different temperatures ranging from 50 to 300°C. The TL emission after annealing for different times at each of these temperatures was measured in the reader. Different combinations of temperature and time were tried.

2.5 Background TL Intensity

For any measurement of TL emission after irradiation, the background is to be determined before irradiation. For determination of background, about 40 chips were cleaned with distilled water and then with acetone so as to get rid of dirt if any. Now the chips were read in the reader without any annealing. Two heating temperatures were arbitrarily

chosen for this purpose, the first one, 225°C and the other, 300°C for the purpose of comparison.

2.6 Irradiation of CR-39 Chips by Beta Particles

Once the backgrounds were determined, the chips were ready for irradiation by beta particles. The chips were annealed at 300°C for different time intervals. If the temperature is not as high as 300°C, there is the likelihood that the background is not brought down to a reasonable level. Six of the chips were kept for background estimation and other six of the chips were irradiated by beta particles. A ⁹⁰Sr reference source manufactured by Nuclear Enterprise Technology (Type 2503/3A) was selected for this purpose. The source had a activity of 370 MBq as on 2/1995. Beta irradiation was performed in air for different doses and then read in the reader. Now an ion chamber (0.6cc) coupled to a Farmer Dosimeter (Model 2670) was introduced into the irradiation chamber for the same length of time and the dose in the air was determined. Care was taken to assure that the chips after annealing were kept in total darkness, as light has considerable effect on the TL properties^[12,16,18,24].

So the chips were annealed at 300°C for a period of 20 seconds in the TLD reader and were then irradiated by beta particles for different time intervals in total darkness and the responses were measured.

2.7 Gamma Irradiation of CR-39 Chips

In this case the chips of CR-39 were annealed at 300°C for a period of 20 seconds in the TLD reader before irradiation. Care was taken to assure that the chips after annealing were kept in total darkness. Gamma irradiation was performed in air using ¹³⁷Cs source for different doses. The source had a strength of 4444 MBq as on 2/1999. The chips were kept at a distance of 50 cm from the source for different periods of time. The dose in the air at this distance from the ¹³⁷Cs source was known from the manufacturer's data. All the irradiated chips were read in the reader for emission intensities.

2.8 Gamma Irradiation of CR-39 Chips in Oxygen Environment

The chips were annealed at 300°C for a period of 20 seconds in the TLD reader and then were irradiated by gamma rays from a ¹³⁷Cs standard source in an oxygen environment. A small plastic can with a rubber stopper fitted with two glass tubes, one acting as gas inlet and the

other as outlet were used for this purpose (Fig.1). The chips were placed in the can and arranged for irradiation using 4444 MBq ^{137}Cs source. The inlet for the gas supply was connected to a cylinder containing oxygen and the flow rate was low. The chips were irradiated for a specific dose under oxygen and then read in the TLD reader. Care was taken to ensure that the chips received minimum light during the irradiation time. The irradiation process was repeated for different time intervals using different sets of annealed chips.

2.9 Gamma Irradiation of CR-39 Chips in Carbon Dioxide Environment

CR-39 chips were prepared for irradiation under carbon dioxide environment. Chips annealed at 300°C for a period of 20 seconds in the TLD reader were used for the purpose. The gamma standard source used was a ^{137}Cs point source. The same set-up used for oxygen was used for carbon dioxide (Fig. 1).

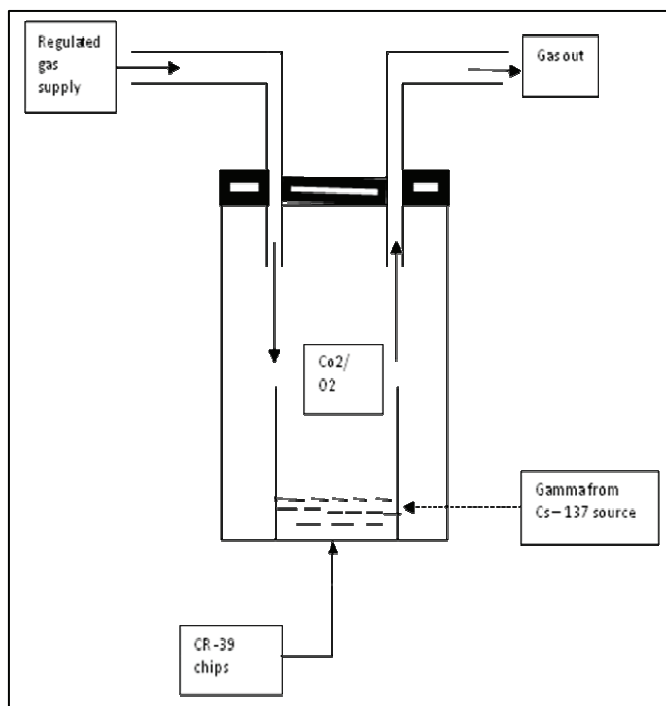

Fig. 1. CR-39 chips irradiated by gamma rays in carbon dioxide /oxygen environment.

3. Results and Discussion

The TL response from any material depends primarily on the TL properties of the material and then on different parameters such as annealing temperatures, heating temperatures, irradiation dose and environmental conditions. Optimization of such parameters is of great importance to achieve best results.

The experimental results showed that the emission intensities increased with heating temperatures and reached a maximum at a temperature of 300°C. The variation of background TL emission with different annealing temperatures showed that the background emission decreases sharply with the annealing temperatures, reaching a value of zero at 300°C, at which stage the chip burns. Annealing for short duration of time at high temperature (20 seconds at 300°C) seems to be comparatively better to have better emissions and to avoid damage of the material. No color change was observed in such a condition. Such a annealing was performed in the TL reader.

The annealed chips were irradiated in air by beta particles and gamma rays at different doses. Table 1 shows the TL emission values from the chips irradiated by beta particles for different doses, while Table 2 shows the TL emission values from chips irradiated by gamma rays at different doses and pre-irradiation annealing at 300°C for 20 seconds in the TL reader. The variation of TL emission intensities with dose for beta particles is shown in Fig. 2. It was observed that the responses at lower doses were erratic. However, at higher doses, the emission intensities increased with doses. The variation of TL emission values with dose from gamma rays is depicted in Fig. 3. It is also observed that at lower doses, the response was erratic. However, at higher doses, the emission intensities increased with increase of dose.

The TL emission values from chips irradiated by gamma rays at different doses in oxygen and carbon dioxide environments are given in Tables 3 and 4, respectively. The variation of TL intensity with dose for CR-39 chips irradiated by gamma rays in oxygen environment and in carbon dioxide environment are shown in Fig. 4 and 5, respectively. It is evident from these figures that the TL response at low doses are erratic as is the case when irradiated in air. At higher doses, the TL response increases with increasing doses.

Table 1. The TL emission values from chips irradiated in air for different times by beta particles from Sr-90 source. (Pre-irradiation annealing at 300⁰C for 20 seconds in the TL reader).

Background (nC)	TL Emission Intensity (nC) after irradiation for						
	5 min	10 min	30 min	60 min	1100 min	1710 min	2520 min
15.54	30.7	37.3	28.0	37.9	45.07	81.59	96.36
16.07	31.1	32.8	38.2	34.0	47.64	82.44	88.36
15.36	31.6	32.7	39.3	41.5	42.8	80.86	95.98
23.18	35.6	34.6	28.7	26.2	39.47	89.35	99.06
15.38	36.4	38.2	31.4	25.9	47.36	77.44	110.9

Average 17.11 33.08 35.12 33.12 33.1 44.46 82.34 98.13

Table 2. The TL emission values from chips irradiated in air for different times by gamma rays from Cs-137 source. (Pre-irradiation annealing at 300⁰C for 20 seconds in the TL reader).

Background (nC)	TL Emission Intensity (nC) after irradiation for						
	5 min	15 min	30 min	60 min	240 min	1220 min	5650 min
20.07	29.9	28.1	20.5	24.9	34.8	40.18	52.92
18.05	23.9	17.3	27.3	22.3	31.2	48.24	58.31
22.25	21.8	17.3	33.5	30.7	24.8	44.34	51.32
25.19	28.9	17.6	27.5	21.4	32.1	51.95	48.18
25.4	26.1	25.4	23.1	20.9	25.3	42.79	47.55

Average 22.19 26.12 23.9 26.38 24.04 29.64 45.5 51.65

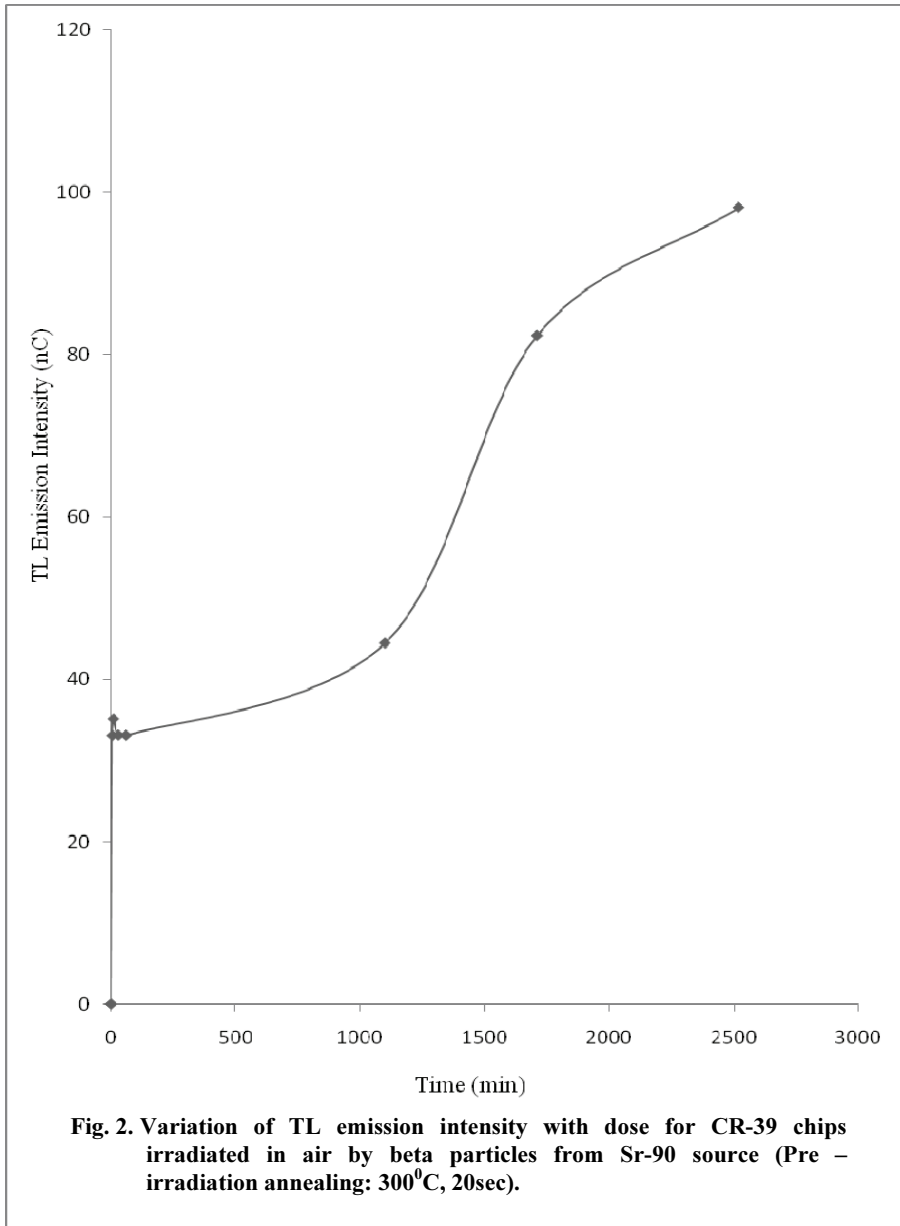

Figure 6 shows the variation of TL emission with dose of CR-39 when irradiated with gamma rays in the presence of air, oxygen and carbon dioxide. It is observed that the dose response of CR-39 when irradiated by gamma in the presence of oxygen gives better results when compared to that in the presence of carbon dioxide. The response in the

presence of carbon dioxide is better than that in the presence of air. The reasons for this type of behavior of the polymer are unclear and merit further investigation.

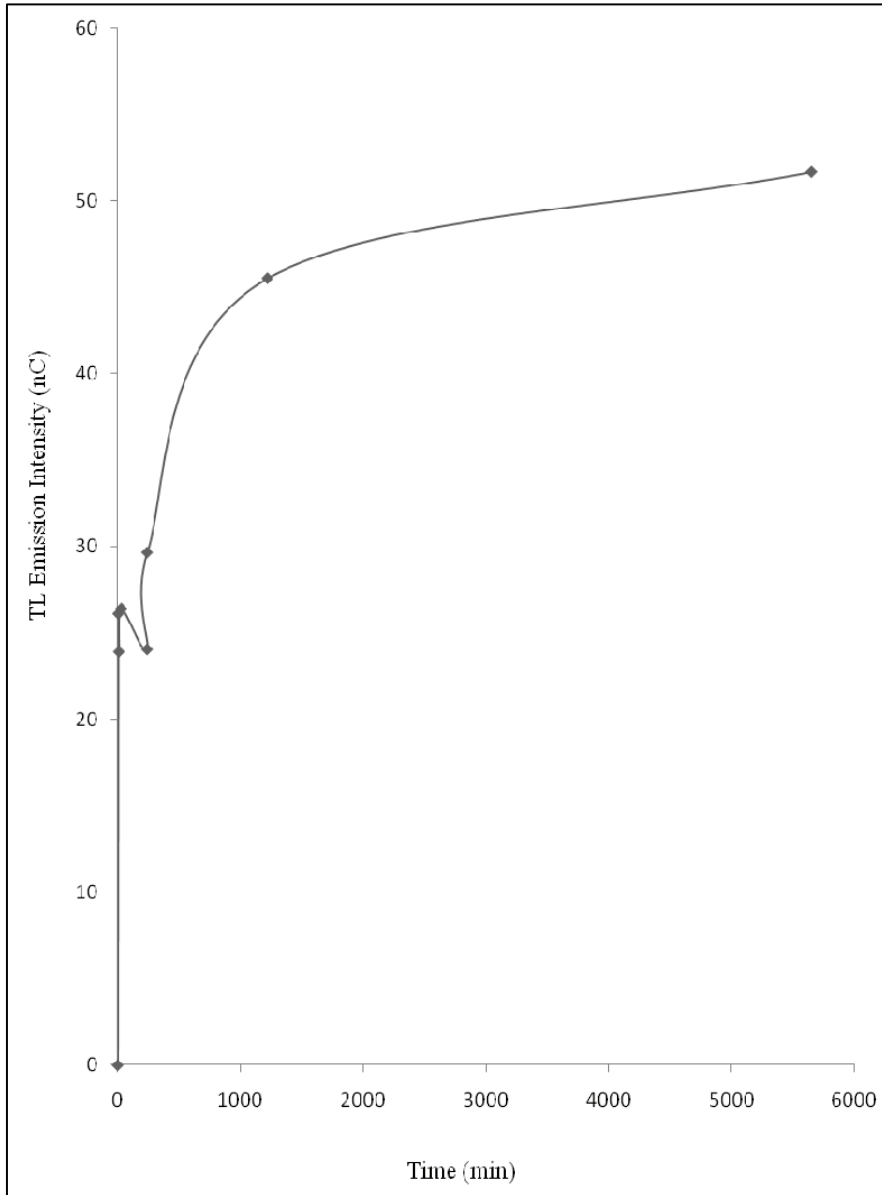

Fig. 3. Variation of TL emission intensity with dose for CR-39 chips irradiated in air by gamma rays from Cs-137 source (Pre-irradiation annealing: 300°C, 20sec).

Table 3. The TL emission values from chips irradiated for different times by gamma rays from Cs-137 source in oxygen environment. (Pre-irradiation annealing at 300°C for 20 seconds in the TL reader).

Background (nC)	TL Emission Intensity (nC) after irradiation for					
	15 min	30 min	75 Min	220 min	330 min	
20.07	36.2	45.4	62.1	86.1	69.9	
18.05	49.5	63.3	52.0	86.5	74.6	
22.25	44.6	44.8	54.7	115.6	81.8	
25.19	43.1	48.2	64.5	110.3	87.1	
25.4	42.1	62.6	58.7	94.2	105.9	
Average	22.19	43.1	52.3	58.4	98.5	83.9

Table 4. The TL emission values from chips irradiated for different times by gamma rays from Cs-137 source in carbon dioxide environment. (Pre-irradiation annealing at 300°C for 20 seconds in the TL reader).

Background (nC)	TL Emission Intensity (nC) after irradiation for					
	15 min	30 min	60 min	200 Min	4040 min	
20.07	28.5	42.0	30.6	29.7	63.9	
18.05	35.9	45.3	33.4	60.5	49.5	
22.25	43.20	41.1	44.7	35.8	43.5	
25.19	40.4	44.1	39.5	45.6	47.3	
25.4	48.3	50.2	41.0	44.8	43.6	
Average	22.19	39.3	44.5	37.8	43.3	49.6

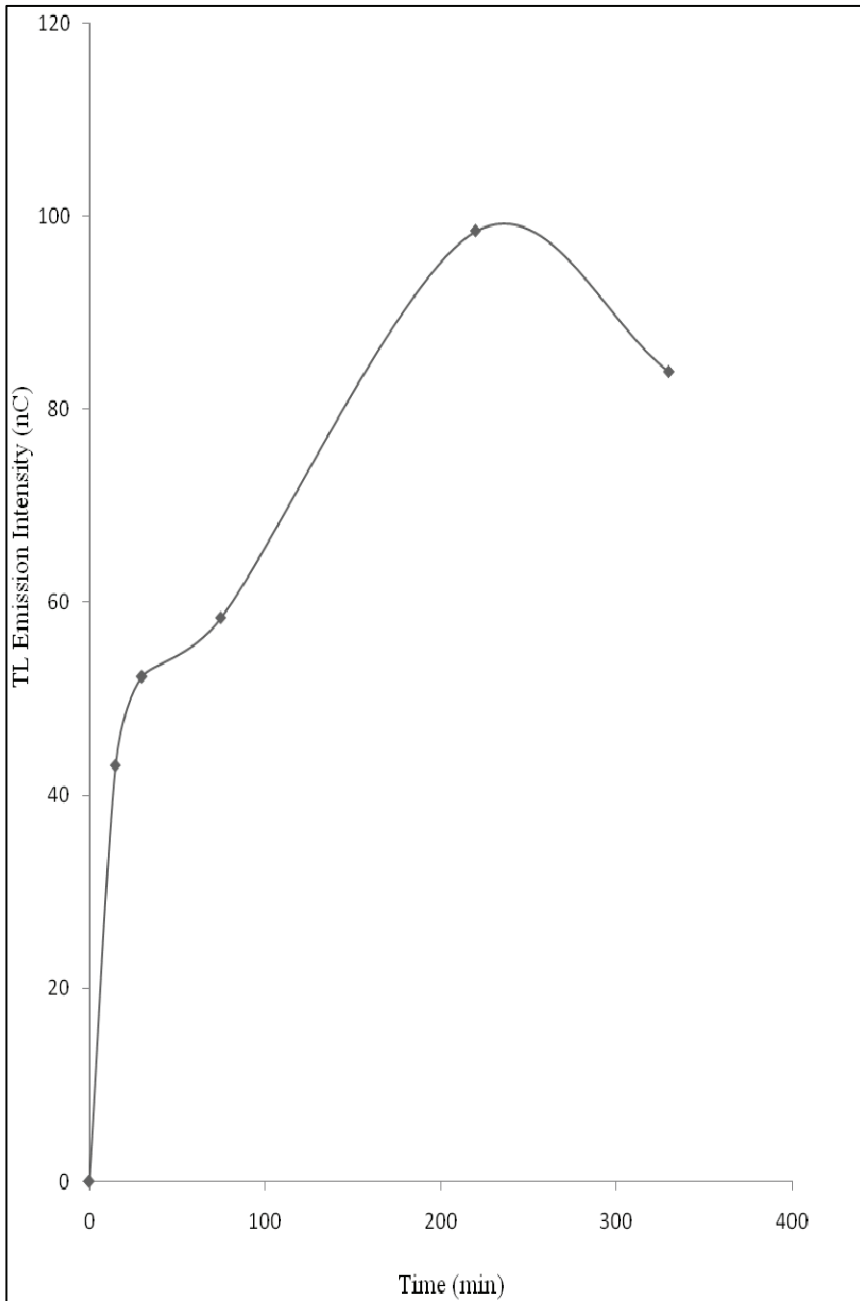

Fig. 4. Variation of TL emission intensity with dose for CR-39 chips irradiated by gamma rays from Cs-137 source in presence of oxygen (Pre -irradiation annealing: 300⁰C, 20sec in the TL reader).

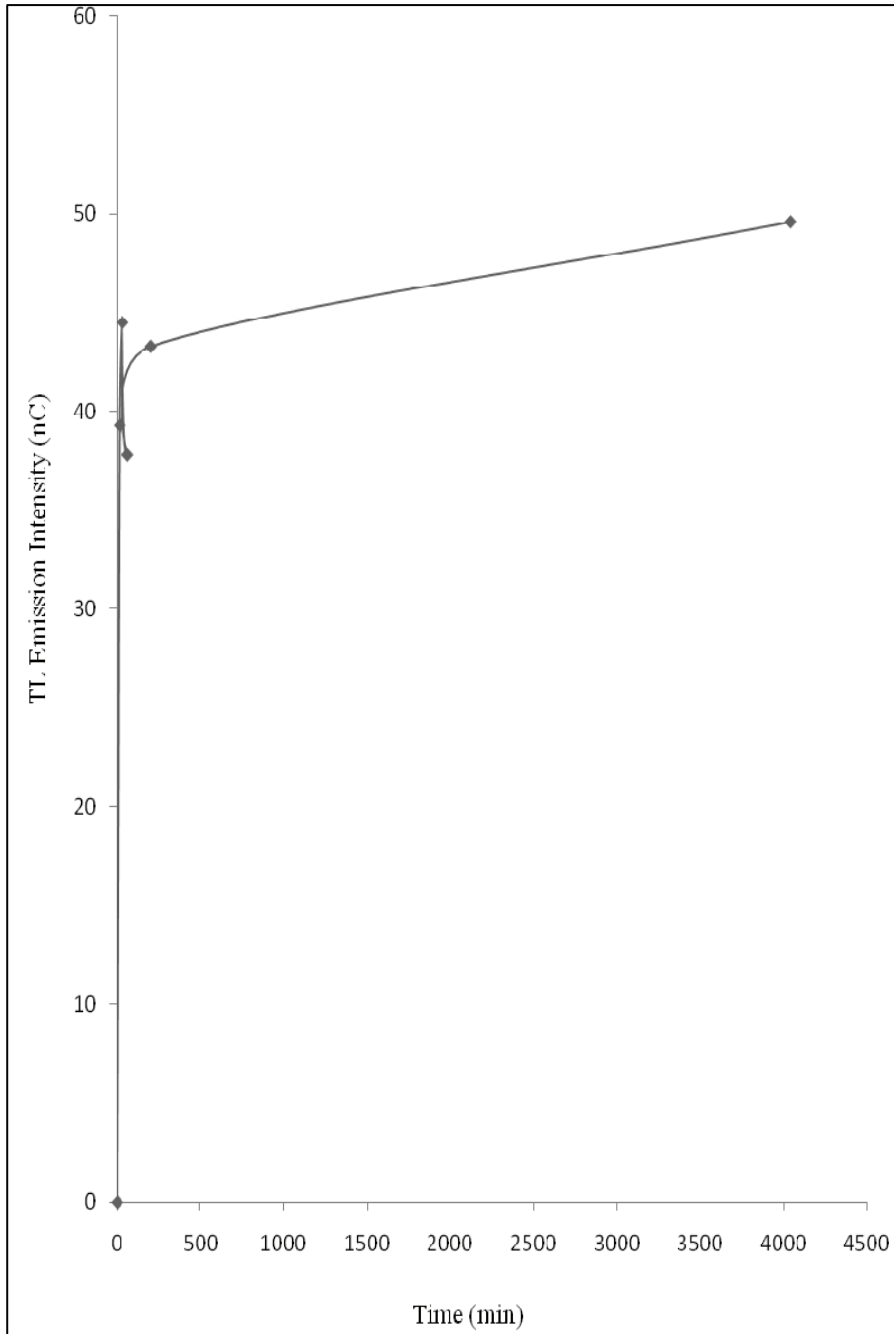

Fig. 5. Variation of TL emission intensity with dose for CR-39 chips irradiated by gamma rays from Cs-137 source in presence of carbon dioxide (Pre-irradiation annealing: 300°C, 20sec in the TL reader).

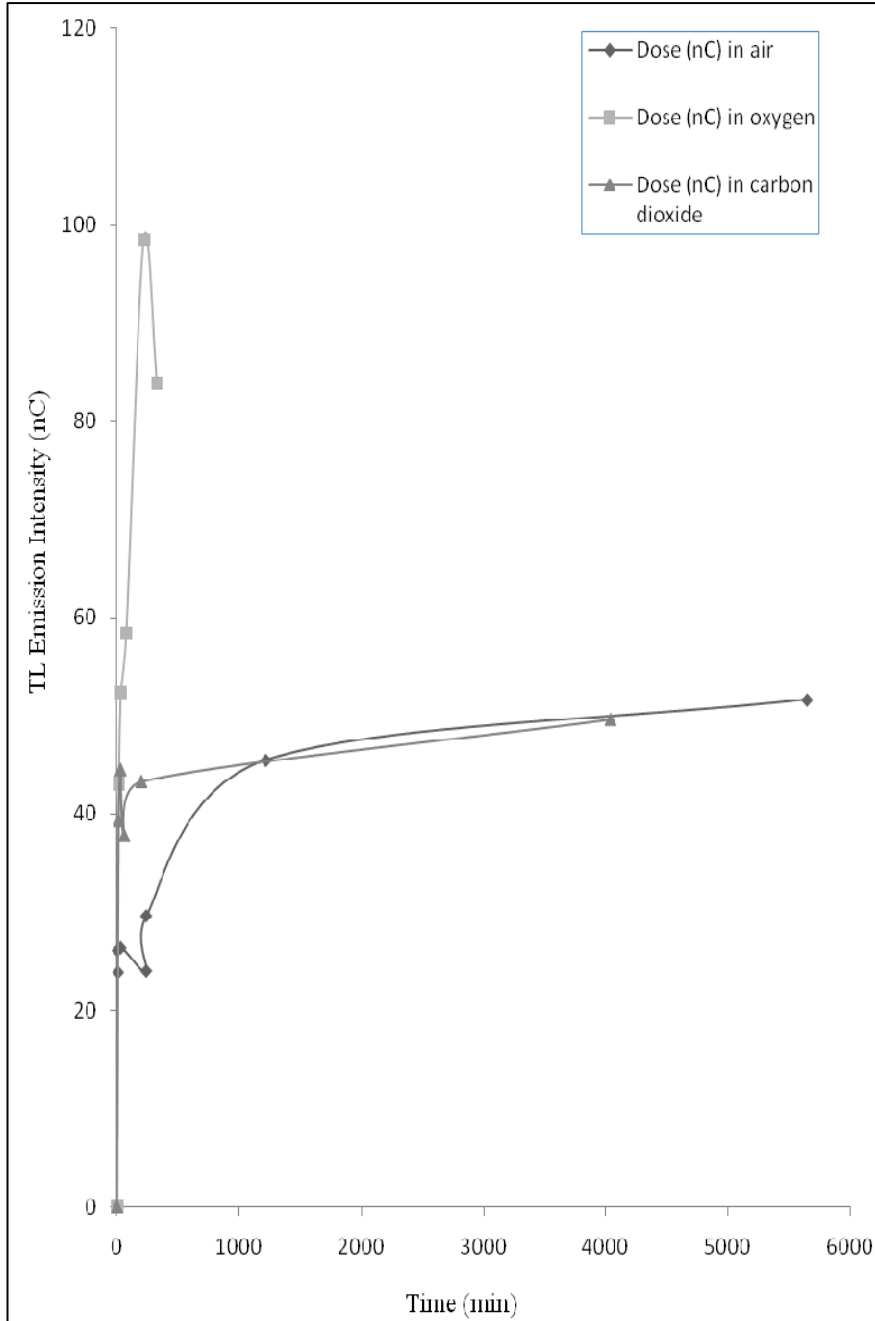

Fig. 6. Variation of TL emission intensity with dose for CR-39 chips irradiated by gamma rays from Cs-137 source in presence of air, oxygen and carbon dioxide (Pre-irradiation annealing: 300°C, 20sec in the TL reader).

4. Conclusion

Thermoluminescent effects of CR-39 may be utilized for measurement of exposures to beta and gamma radiations. The TL response of CR-39 at lower doses seem to be erratic while at higher doses, the response increases with dose. Exposure of CR-39 for large doses in the presence of oxygen and carbon dioxide enhances the TL properties of CR-39. Dose response of CR-39 when irradiated by gamma rays in the presence of oxygen gives better results compared to that in the presence of carbon dioxide. The response in the presence of carbon dioxide is better than that in the presence of air. As the effects of radiation are manifested only at higher doses, the material may not be very useful for personal dosimetry. However, it might require further study with more optimization of the parameters and the conditions to disregard this material to be used as a personal dosimeter.

References

- [1] **Bedogni, R. and Fantuzzi, E.**, A personal neutron monitoring system based on CR-39 recoil proton track detectors, *Radiat. Prot. Dosim.*, **101**: 183 -1889 (2002).
- [2] **Csige, I., Hunyadi, I. and Charvat, J.**, Environmental effects on sensitivity of different types of CR-39, *Nucl.Tracks Radiat. Meas.*, **19**:151-154(1991).
- [3] **Fantuzii, E., Mariotti, F. and Falangi, G.**, Performance of CR-39 with addition of DOP for fast neutron dosimetry, *Nucl. Tracks Radiat. Meas.*, **38**: 475-480 (2003).
- [4] **Farid, S. M.**, A study on the radon concentrations in drinking water in Saudi Arabia and the associated health effects, *J. Environ. Radioactivity*, **38**: 97- 101 (1998).
- [5] **Al-Jarallah, M.I. , Rehman, F. , Musazay, A. and Aksoy, A.**, Correlation between radon exhalation and radium content in granite samples used as construction material in Saudi Arabia , *Nucl. Tracks Radiat. Meas.* , **40**: 625 – 629 (2005).
- [6] **Erees, F.S., Yener, G., Salk, M. and Ozbal, O.**, Measurement of radon content in soil gas and in thermal wayers in Western Turkey, *Nucl. Tracks Radiat. Measur.*, **41**: 354 – 361 (2006).
- [7] **Zaki, M.F. and El-Shaer, Y.H. ,** Particularization of alpha contamination using CR- 39 track detectors , *Paramana* , **69** (4): 567 – 574 (2007).
- [8] **Al- Azmi , D. , Abu-Shady, A.I., Sayed, A.M. and Al-Zayed, A. ,** Indoor radon in Kuwait, *Health Phys.* , **94** (1): 49 – 56 (2008).
- [9] **Heins, T. and Enge, W.**, Oxygen effect on the etch rate in CR-39 polymer, *Nucl. Tracks Radiat. Meas*, **12**: 87-92 (1996).
- [10] **Hemmerich, K.J.**, Polymer materials selection for radiation- sterilization products, *Medical Devices & Diagnostic Industry Magazine*, **5**: 20-31 (2000).
- [11] **Isabey, R., Duverger, E., Decossas, J.L. and Varielle, J.C.**, Theoretical and experimental study of the CR-39 behavior under electron beam, *Nucl. Tracks Radiat. Measur.*, **31**: 85-90 (1999).
- [12] **Kumar, S. Chander, S., Yadov, J.S, and Sharma, A.P.**, Some environmental effect studies on CR-39 polymer , *Nucl. Tracks Radiat. Meas.*, **12**:129-135 (1996).
- [13] **Malek, M. A. and Chong, C.S.**, CO₂ diffusion from X-ray and γ -ray irradiated CR-39 plastic, *Nucl. Tracks Radiat. Measur.*, **35** : 203-207, (2002).

- [14] **Malek, M. A., Chang, C.S. and Renreng, A.** Generation of CO₂ in γ - ray irradiated CR-39 plastic, *Nucl. Tracks Radiat. Meas.* **35**:109 -114 (2002).
- [15] **Malek, M. A., Renreng, A. and Chong, C.S.,** Mechanistic model for bond scission in polymeric system by radiation, *Radiat. Phys. & Chem.* , **60**: 603-608 (2001).
- [16] **Mehta, K., Fouchi, P., Lavalle, M. and Kovacs, A.,** Behavior of non-conducting plastics under e-beam irradiation, *Radiat. Phys. & Chem.* , **63** :745-750 (2002).
- [17] **Oda, K., Yoshida, K., Yamauchi, T. and Tagawa, S.,** Effect of low-LET radiations on CR-39 track detectors, *Nucl. Tracks Radiat. Measur.*,**28**: 85-90 (1997).
- [18] **Partwood, T., Henshaw, D.L. and Stejny, J.,** Ageing effects in CR-39, *Nucl. Tracks Radiat. Meas.*,**12**: 109-105 (1999).
- [19] **Reichmanis, E., Curtis, W.F., O'Donnell, J.H. and David, J.T.,** *Irradiation of Polymeric materials: Process, Mechanism and Application*, American Chemical Society, Washington, USA, 1984.
- [20] **Singh, S. and Prasher, S.,** UV-VIS spectroscopic and etching studies of IR exposed CR-39 plastic track detector , *Nucl. Instrum. Method*, **215**: 169-174 (2004).
- [21] **Sinha, D. and Dwivedi, K. K.,** Modification of radiation detection response of PADC track detectors by protons, *Radiat. Phys. & Chem.*, **53**: 99 -103 (1998).
- [22] **Sinha, D., Swu, T., Tripathy, S.P. and Dwivedi, K. K.,** Gamma effect on track properties on PADC detector, *Nucl. Tracks Radiat. Meas.*,**36**:229-332, (2003).
- [23] **Yamauchi, T., Nakai, H., Somaki, Y. and Oda, K.,** Formation of CO₂ gas and OH groups in CR-39 plastics due to gamma ray and ion irradiation , *Nucl. Tracks Radiat. Meas.*, **38**: 99 -104 (2003).
- [24] **Yamauchi, T., Oda, K., Honda, Y. and Tagawa, S.,** Dose-rate effects on the bulk-etch rate of CR-39 detector exposed to low-LET radiations, *Nucl. Tracks Radiat. Meas.*, **31**: 121-125 (1999).
- [25] **Kobzev, A.P., El-Asser, M.R., El-Halem, A.A., Ghaphar, U.S.A. and Salama, T.A. ,** Effect of gamma rays on fast neutron registration in CR-39, *Nucl. Tracks Radiat. Meas.*, **37**: 201-204 (2003).
- [26] **Oda, K., Imasaka, Y., Tsukahara, T., Yamauchi, T., Nakane, Y. and Yamaguchi, Y.** Radiator effect on plastic nuclear track detectors for high-energy neutrons, *Nucl. Tracks Radiat. Meas.*, **36**: 119 –124 (2003).
- [27] **Shweikani, R., Raja, G. and Sawaf, A.A.** The possibility of using plastic detectors CR-39 as UV dosimeters, *Nucl. Tracks Radiat. Meas.*, **35**: 282-285 (2002).
- [28] **Singh, S. and Prasher, S.** UV-VIS spectroscopic and etching studies of IR exposed CR-39 plastic track detector, *Nucl. Instrum. Methods*, **215**: 169-173 (2004).
- [29] **Chong, C.S., Ishak, I., Mahat, R.H. and Amin, Y.M.** UV-VIS and FTIR spectral studies of CR-39 plastics irradiated with X-rays, *Nucl. Tracks Radiat. Meas.*, **28**: 119-122 (1997).
- [30] **Sinha, D., Mishra, R., Tripathy, T.S. and Dwivedi, K.K.** Effect of high gamma doses on the etching behavior of different types of PADC detectors, *Nucl. Tracks Radiat. Meas.*, **33**: 139-143 (2001).
- [31] **Saad, A.F., Atwa, S.T., Yasuda, N. and Fujii, M.** FT-IR spectroscopy of carbon dioxide in CR-39 and SR-90 track detectors irradiated with ions and gamma- rays at different energies and fluencies, *Nucl. Tracks Radiat. Meas.*, **34**: 51-54 (2001).

استخدام الكاشف النووي CR - 39 في مجال القياسات الإشعاعية

زهير بن عبدالله طيب

قسم الهندسة النووية - كلية الهندسة - جامعة الملك عبدالعزيز
ص.ب: ٨٠٢٠٤ جدة ٢١٥٨٩ - المملكة العربية السعودية
ztayyeb@hotmail.com

المستخلص. تناقش هذه الورقة العلمية نتائج دراسة الحث
الحرصوي لمادة البوليمر (CR - 39) عند تعريضها لأشعة "جاما"
وكذلك لجسيمات "بيتا".

إن توفر ورخص ثمن مادة البوليمر (CR - 39)، يجعل من
دراسة جدوى استخدامها لأغراض القياسات الإشعاعية الشخصية
أمراً جديراً بالبحث. وقد تم تقسيم الشرائح إلى مجموعتين: تم
تعريض المجموعة الأولى من شرائح الـ (CR - 39) ذات أبعاد
٣م × ٣م لأشعة "جاما" من مصدر "سيزيوم - ١٣٧" (Cs -
137): وتم تعريض المجموعة الثانية لجسيمات "بيتا" من مصدر
"سترنشيوم - ٩٠" (Sr - 90)، ثم تمت قراءة الانبعاثات الحرصوية
الصادرة منها باستخدام قارئ (TLD) هارشو ٤٥٠٠ (Harshaw
4500). تم تسخين شرائح الـ (CR - 39) عند درجات حرارة
وفترات زمنية مختلفة لمعرفة درجة التسخين والفترة الزمنية المثلى
لمعالجة الشرائح وتنظيفها لأقصى حد. تمت دراسة درجات حرارة
التسخين على مدى واسع في قارئ (TL) لتحديد درجة الحرارة
الأفضل الممكنة لتسخين شرائح الـ (CR - 39). إن احتمالية تعزيز
خاصية الانبعاث الحرصوي لشرائح (CR - 39) عند تعريضها

لأشعة "جاما" في وجود عنصري الأكسجين وثاني أكسيد الكربون قد تمت دراستها، وقد تبين لنا أن التحسن في خاصية الانبعاث الحرضوني لشرائح (CR - 39) عند تعريضها لجرعة من أشعة "جاما" في وجود الأكسجين أفضل منه في وجود ثاني أكسيد الكربون. كما وُجد أن التحسن في خاصية الانبعاث الحرضوني لشرائح (CR - 39) في وجود ثاني أكسيد الكربون أفضل منه في وجود الهواء.

كلمات مفتاحية: بوليمر CR - 39 ؛ الانبعاث الحرضوني؛ ^{137}Sr ؛ تأثير الأكسجين؛ تأثير ثاني أكسيد الكربون.